

A  
B  
C

# SECTION RAX

## REAR AXLE

RAX

### CONTENTS

<b>SYMPTOM DIAGNOSIS</b> ..... 2	Inspection ..... 6	F
<b>NOISE, VIBRATION AND HARSHNESS (NVH) TROUBLESHOOTING</b> ..... 2	<b>REMOVAL AND INSTALLATION</b> ..... 7	
NVH Troubleshooting Chart ..... 2	<b>REAR WHEEL HUB AND HOUSING</b> ..... 7	G
<b>PRECAUTION</b> ..... 3	Exploded View ..... 7	
<b>PRECAUTIONS</b> ..... 3	Removal and Installation ..... 8	H
Precautions for Drive Shaft ..... 3	Inspection ..... 9	
<b>PREPARATION</b> ..... 4	<b>REAR DRIVE SHAFT</b> ..... 11	
Precautions for Drive Shaft ..... 3	Exploded View ..... 11	I
<b>PREPARATION</b> ..... 4	Removal and Installation ..... 11	
Special Service Tool ..... 4	Disassembly and Assembly ..... 12	J
Commercial Service Tool ..... 4	Inspection ..... 16	
<b>PERIODIC MAINTENANCE</b> ..... 5	<b>SERVICE DATA AND SPECIFICATIONS (SDS)</b> ..... 17	K
<b>REAR WHEEL HUB AND HOUSING</b> ..... 5	<b>SERVICE DATA AND SPECIFICATIONS (SDS)</b> ..... 17	L
Inspection ..... 5	Wheel Bearing ..... 17	
<b>REAR DRIVE SHAFT</b> ..... 6	Drive Shaft ..... 17	M
		N
		O
		P

# NOISE, VIBRATION AND HARSHNESS (NVH) TROUBLESHOOTING

< SYMPTOM DIAGNOSIS >

## SYMPTOM DIAGNOSIS

### NOISE, VIBRATION AND HARSHNESS (NVH) TROUBLESHOOTING

#### NVH Troubleshooting Chart

INFOID:000000004670155

Use chart below to find the cause of the symptom. If necessary, repair or replace these parts.

Reference page			Possible cause and SUSPECTED PARTS														
			Excessive joint angle	Joint sliding resistance	Imbalance	Improper installation, looseness	Parts interference	PROPELLER SHAFT	DIFFERENTIAL	REAR AXLE AND REAR SUSPENSION	REAR AXLE	TIRE	ROAD WHEEL	DRIVE SHAFT	BRAKE	STEERING	
Symptom	DRIVE SHAFT	Noise	x	x				x	x	x	x	x	x		x	x	
		Shake	x		x			x		x	x	x	x		x	x	
	REAR AXLE	Noise				x	x	x	x	x		x	x	x	x	x	x
		Shake				x	x	x		x		x	x	x		x	x
		Vibration				x	x	x		x		x		x			x
		Shimmy				x	x			x		x	x			x	x
		Judder				x				x		x	x			x	x
		Poor quality ride or handling				x	x			x		x	x				
	Reference page			—	<a href="#">RAX-16</a>	—	<a href="#">RAX-7</a>	—	NVH in DLN section.	NVH in DLN section.	NVH in RAX and RSU sections.	Refer to REAR AXLE in this chart.	NVH in WT section.	NVH in WT section.	Refer to DRIVE SHAFT in this chart.	NVH in BR section.	NVH in ST section.

x: Applicable

# PRECAUTIONS

< PRECAUTION >

## PRECAUTION

### PRECAUTIONS

#### Precautions for Drive Shaft

INFOID:000000004670156

- Observe the following precautions when disassembling and assembling drive shaft.
- Never disassemble joint sub-assembly because it is non-overhaul parts.
- Perform work in a location which is as dust-free as possible.
- Clean the parts, before disassembling and assembling.
- Prevent the entry of foreign objects during disassembly of the service location.
- Reassemble disassembled parts carefully in the correct order. If work is interrupted, a clean cover must be placed over parts.
- Use paper waste. Fabric shop cloths must not be used because of the danger of lint adhering to parts.
- Clean disassembled parts (except for rubber parts) with kerosene which shall be removed by blowing with air or wiping with paper waste.

A

B

C

RAX

E

F

G

H

I

J

K

L

M

N

O

P

# PREPARATION

< PREPARATION >

## PREPARATION

### PREPARATION

#### Special Service Tool

INFOID:000000004670157

The actual shapes of Kent-Moore tools may differ from those of special service tools illustrated here.

Tool number (Kent-Moore No.) Tool name	Description
KV38100500 ( - ) Drift a: 80 mm (3.15 in) dia. b: 60 mm (2.36 in) dia.	Installing drive shaft plug
KV38102200 ( - ) Drift a: 90 mm (3.54 in) dia. b: 31 mm (1.22 in) dia.	Installing drive shaft plug
KV40107300 ( - ) Boot band crimping tool	Installing boot band

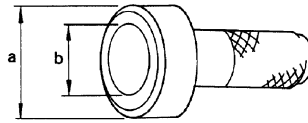

ZZA0701D

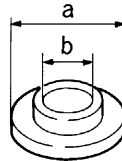

ZZA0920D

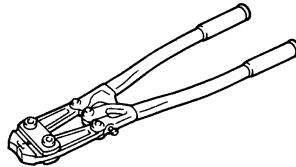

ZZA1229D

#### Commercial Service Tool

INFOID:000000004670158

Tool name	Description
Power tool	Loosening bolts and nuts

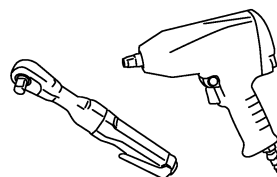

PBIC0190E

# REAR WHEEL HUB AND HOUSING

< PERIODIC MAINTENANCE >

## PERIODIC MAINTENANCE

### REAR WHEEL HUB AND HOUSING

#### Inspection

INFOID:000000004670159

#### MOUNTING INSPECTION

Make sure the mounting conditions (looseness, back lash) of each component and component conditions (wear, damage) are normal.

#### WHEEL BEARING INSPECTION

- Move wheel hub and bearing assembly in the axial direction by hand. Make sure there is no looseness of wheel bearing.

#### Standard

**Axial end play** : Refer to [RAX-17, "Wheel Bearing"](#).

- Rotate wheel hub and bearing assembly and make sure that is no unusual noise or other irregular conditions. If there is any of irregular conditions, replace wheel hub and bearing assembly.

A  
B  
C  
RAX  
E  
F  
G  
H  
I  
J  
K  
L  
M  
N  
O  
P

## REAR DRIVE SHAFT

< PERIODIC MAINTENANCE >

---

### REAR DRIVE SHAFT

#### Inspection

INFOID:000000004670160

- Check drive shaft mounting point and joint for looseness and other damage.
- Check boot for cracks and other damage.

**CAUTION:**

**Replace entire drive shaft assembly when noise or vibration occurs from drive shaft.**

# REAR WHEEL HUB AND HOUSING

< REMOVAL AND INSTALLATION >

## REMOVAL AND INSTALLATION

### REAR WHEEL HUB AND HOUSING

Exploded View

INFOID:000000004670161

WITHOUT ADJUSTING CAP AND SPRING WASHER FOR WHEEL HUB LOCK NUT

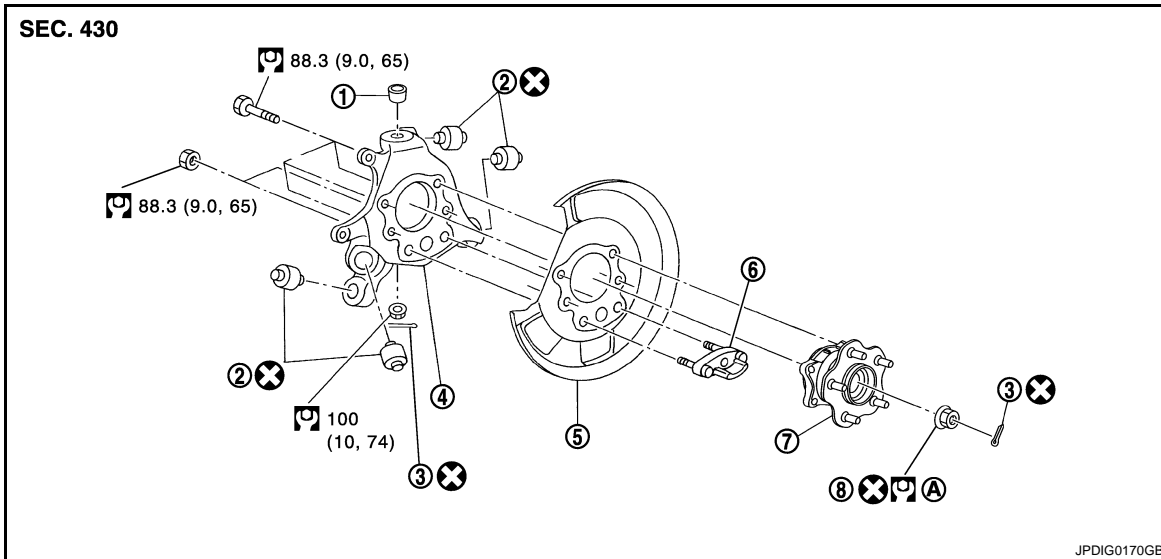

- |                                   |                       |                 |
|-----------------------------------|-----------------------|-----------------|
| 1. Ball seat                      | 2. Bushing            | 3. Cotter pin   |
| 4. Axle housing                   | 5. Back plate         | 6. Anchor block |
| 7. Wheel hub and bearing assembly | 8. Wheel hub lock nut |                 |

A. Tightening must be done following the installation procedure. Refer to [RAX-8, "Removal and Installation"](#).

Refer to [GI-4, "Components"](#) for symbols in the figure.

WITH ADJUSTING CAP AND SPRING WASHER FOR WHEEL HUB LOCK NUT

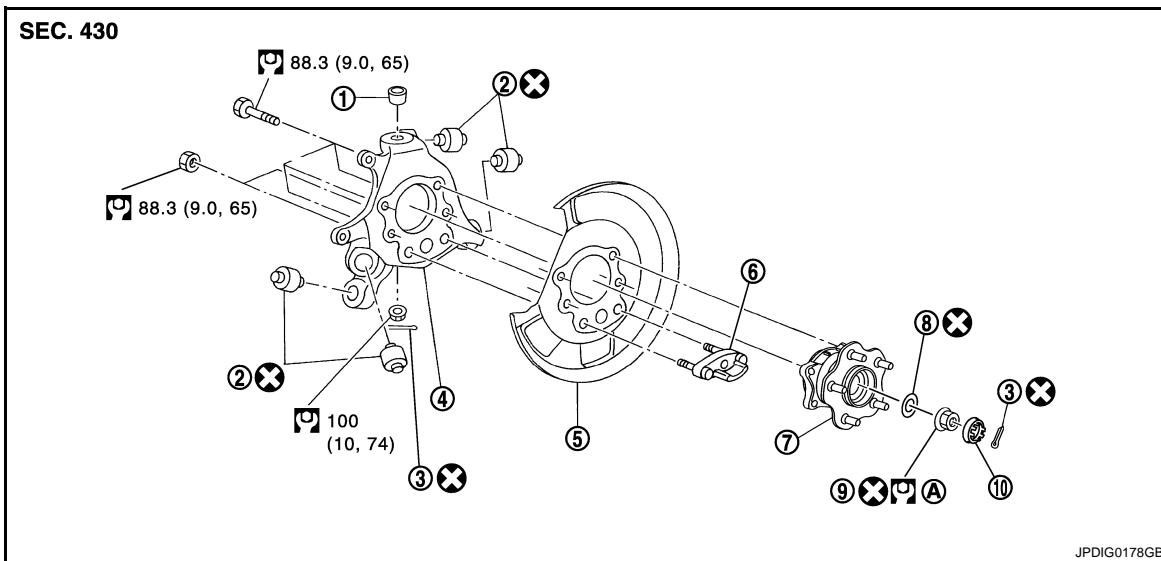

- |                                   |                  |                       |
|-----------------------------------|------------------|-----------------------|
| 1. Ball seat                      | 2. Bushing       | 3. Cotter pin         |
| 4. Axle housing                   | 5. Back plate    | 6. Anchor block       |
| 7. Wheel hub and bearing assembly | 8. Spring washer | 9. Wheel hub lock nut |
| 10. Adjusting cap                 |                  |                       |

# REAR WHEEL HUB AND HOUSING

## < REMOVAL AND INSTALLATION >

- A. Tightening must be done following the installation procedure. Refer to [RAX-8, "Removal and Installation"](#).

Refer to [GI-4, "Components"](#) for symbols in the figure.

## Removal and Installation

INFOID:000000005787944

### REMOVAL

#### Wheel Hub and Bearing Assembly

1. Remove tire from vehicle with power tool.
2. Remove caliper assembly. Hang caliper assembly in a place where it will not interfere with work. Refer to [BR-64, "BRAKE CALIPER ASSEMBLY \(FRONT CALIPER 1 PISTON TYPE\) : Exploded View"](#) (1 piston type), [BR-68, "BRAKE CALIPER ASSEMBLY \(FRONT CALIPER 2 PISTON TYPE\) : Exploded View"](#) (2 piston type).

**CAUTION:**

**Never depress brake pedal while brake caliper is removed.**

3. Remove disc rotor. Refer to [BR-65, "BRAKE CALIPER ASSEMBLY \(FRONT CALIPER 1 PISTON TYPE\) : Removal and Installation"](#) (1 piston type), [BR-69, "BRAKE CALIPER ASSEMBLY \(FRONT CALIPER 2 PISTON TYPE\) : Removal and Installation"](#) (2 piston type).
4. Remove cotter pin and adjusting cap (if equipped), then loosen wheel hub lock nut with a power tool.
5. Put matching mark (A) on drive shaft and wheel hub and bearing assembly.

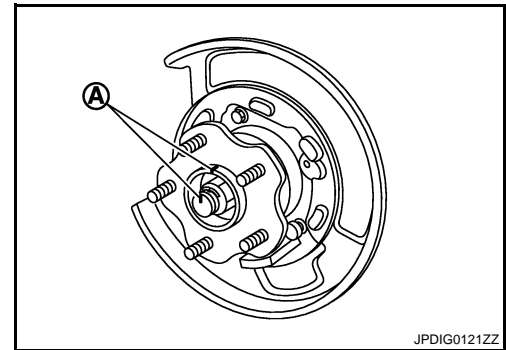

6. Patch wheel hub lock nut with a piece of wood. Hammer the wood to disengage wheel hub and bearing assembly from drive shaft. Take out the wheel hub lock nut and spring washer (if equipped).

**CAUTION:**

- **Never place drive shaft joint at an extreme angle. Also be careful not to overextend slide joint.**
- **Never allow drive shaft to hang down without support for counterpart such as joint sub-assembly, and other parts.**

**NOTE:**

Use a suitable puller, if the wheel hub and bearing assembly and drive shaft cannot be separated even after performing the above procedure.

7. Remove cotter pin, then loosen suspension arm mounting nut of axle housing.
8. Remove the wheel hub and bearing assembly.

#### Axle Housing

1. Remove wheel hub and bearing assembly.
2. Remove parking brake shoe and parking brake cable from back plate. Refer to [PB-9, "Exploded View"](#).
3. Remove mounting nuts in stabilizer side of stabilizer connecting rod with power tool. Refer to [RSU-21, "Exploded View"](#).
4. Remove axle side nuts and bolts on radius rod. Refer to [RSU-17, "Exploded View"](#).
5. Remove coil spring. Refer to [RSU-8, "Exploded View"](#).
6. Set suitable jack under axle housing.
7. Remove shock absorber mounting bolts and nuts (axle housing side) with power tool. Refer to [RSU-11, "Exploded View"](#).
8. Remove front lower link nuts and bolts (axle housing side), separate front lower link from axle housing. Refer to [RSU-19, "Exploded View"](#).



# REAR WHEEL HUB AND HOUSING

## < REMOVAL AND INSTALLATION >

9. Separate suspension arm from axle housing so as not to damage ball joint boot using ball joint remover, and then remove axle housing from the vehicle.
- CAUTION:**
- Temporarily tighten nuts to prevent damage to threads and to prevent the ball joint remover from coming off.
  - Never place drive shaft joint at an extreme angle. Also be careful not to overextend slide joint.
  - Never allow drive shaft to hang down without support for counterpart such as joint sub-assembly, and other parts.
10. Remove anchor block mounting nuts, and then remove anchor block and back plate from axle housing.

## INSTALLATION

Note the following, and install in the reverse order of removal.

- Clean the matching surface of wheel hub lock nut and wheel hub and bearing assembly.

**CAUTION:**

Never apply lubricating oil to these matching surface.

- Clean the matching surface of drive shaft and wheel hub and bearing assembly. And then apply paste [service parts (440037S000)] to surface (A) of joint sub-assembly of drive shaft.

**CAUTION:**

Apply paste to cover entire flat surface of joint sub-assembly of drive shaft.

Amount paste      1.0 – 3.0 g (0.04 – 0.10 oz)

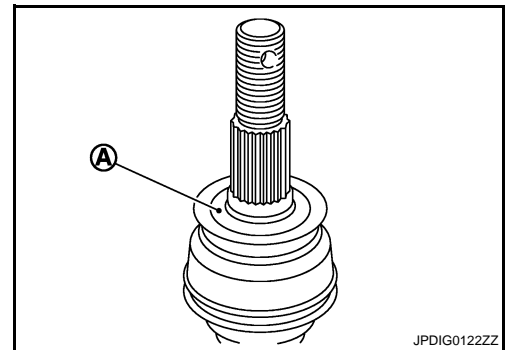

- Use the following torque range for tightening the wheel hub lock nut.

Without adjusting cap and spring washer

 : 180 N·m (18.4 kg·m, 133 ft·lb) – 185 N·m (18.8 kg·m, 136 ft·lb)

With adjusting cap and spring washer

 : 100 N·m (10 kg·m, 74 ft·lb) – 105 N·m (11 kg·m, 77 ft·lb)

**CAUTION:**

- Since the drive shaft is assembled by press-fitting, use the tightening torque range for the wheel hub lock nut.
  - Be sure to use torque wrench to tighten the wheel hub lock nut. Never use a power tool.
- NOTE:**
- Wheel hub lock nut tightening torque does not over torque for avoiding axle noise, and does not less than torque for avoiding looseness.
- Perform the final tightening of each of parts under unladen conditions, which were removed when removing wheel hub and bearing assembly and axle housing.
  - When installing the spring washer, face the identification paint mark to the wheel hub and bearing assembly side. (With adjusting cap and spring washer for wheel hub lock nut)
  - When installing the adjusting cap, check that there must be no play. (With adjusting cap and spring washer for wheel hub lock nut)
  - Never reuse cotter pin, wheel hub lock nut, spring washer (if equipped), and bushing.

## Inspection

INFOID:000000004670163

### INSPECTION AFTER REMOVAL

Wheel Hub and Bearing Assembly

Check the wheel hub and bearing assembly for wear, cracks, and damage. Replace if necessary.

Axle Housing

Check the axle housing for wear, cracks, and damage. Replace if necessary.

Ball Joint Inspection

Check for boot breakage, axial looseness, and torque of suspension arm ball joint. Refer to [RSU-15. "Inspection"](#).

A  
B  
C  
RAX  
E  
F  
G  
H  
I  
J  
K  
L  
M  
N  
O  
P

## REAR WHEEL HUB AND HOUSING

< REMOVAL AND INSTALLATION >

---

### INSPECTION AFTER INSTALLATION

- Check wheel alignment. Refer to [RSU-6, "Inspection"](#).
- Adjust neutral position of steering angle sensor. Refer to [BRC-8, "ADJUSTMENT OF STEERING ANGLE SENSOR NEUTRAL POSITION : Special Repair Requirement"](#).
- Adjust parking brake operation (stroke). Refer to [PB-3, "PEDAL TYPE : Inspection and Adjustment"](#) (pedal type), [PB-4, "LEVER TYPE : Inspection and Adjustment"](#) (lever type).

# REAR DRIVE SHAFT

< REMOVAL AND INSTALLATION >

## REAR DRIVE SHAFT

Exploded View

INFOID:000000004670164

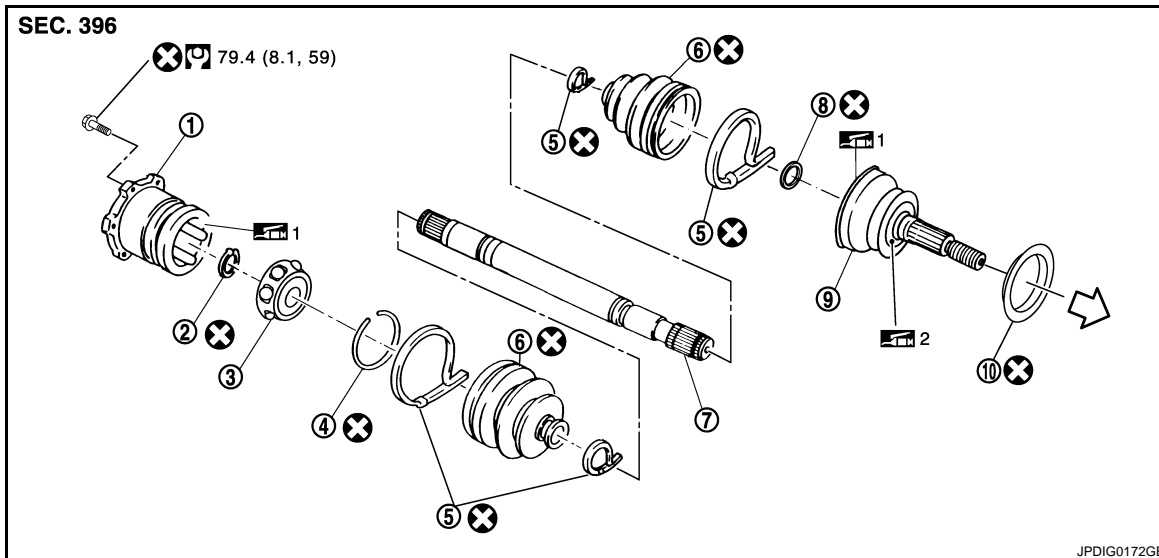

- |                 |                  |   |
|-----------------|------------------|---|
| 1. Housing      | 2. Snap ring     | 3. Ball cage/steel ball/inner race assembly |
| 4. Stopper ring | 5. Boot band     | 6. Boot                                     |
| 7. Shaft        | 8. Circular clip | 9. Joint sub-assembly                       |
| 10. Dust shield |                  |   |

⇐: Wheel side

1: NISSAN genuine grease or an equivalent.

2: Apply paste [service parts (440037S000)].

Refer to [GI-4, "Components"](#) for symbols not described on the above.

## Removal and Installation

INFOID:000000005787960

### REMOVAL

- Remove tire from vehicle with power tool.
- Remove cotter pin and adjusting cap (if equipped), then loosen wheel hub lock nut with power tool.
- Put matching mark (A) on drive shaft and wheel hub and bearing assembly.
- Remove main muffler and center muffler. Refer to [EX-5, "Exploded View"](#).
- Patch wheel hub lock nut with a piece of wood. Hammer the wood to disengage wheel hub and bearing assembly from drive shaft. Take out the wheel hub lock nut and spring washer (if equipped).

#### CAUTION:

- Never place drive shaft joint at an extreme angle. Also be careful not to overextend slide joint.
- Never allow drive shaft to hang down without support for counterpart such as joint sub-assembly, and other parts.

#### NOTE:

Using a suitable puller if the wheel hub and bearing assembly and drive shaft cannot be separated even after performing the above procedure.

- Remove mounting bolts between side flange and drive shaft.

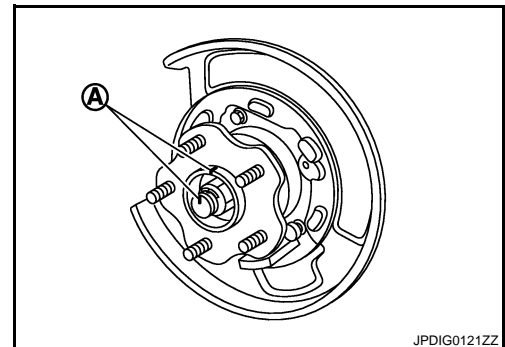

# REAR DRIVE SHAFT

## < REMOVAL AND INSTALLATION >

### INSTALLATION

Note the following, and install in the reverse order of removal.

- Clean the matching surface of wheel hub lock nut and wheel hub and bearing assembly.

**CAUTION:**

**Never apply lubricating oil to these matching surface.**

- Clean the matching surface of drive shaft and wheel hub and bearing assembly. And then apply paste [service parts (440037S000)] to surface (A) of joint sub-assembly of drive shaft.

**CAUTION:**

**Apply paste to cover entire flat surface of joint sub-assembly of drive shaft.**

**Amount paste      1.0 – 3.0 g (0.04 – 0.10 oz)**

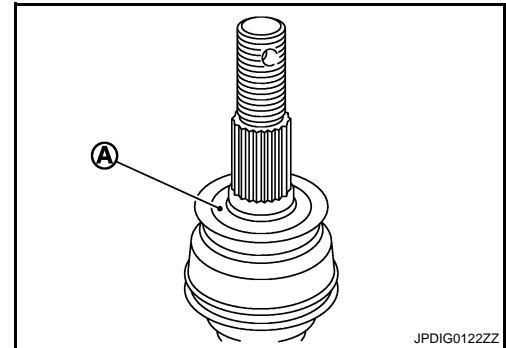

- Use the following torque range for tightening the wheel hub lock nut.

Without adjusting cap and spring washer

 : **180 N·m (18.4 kg·m, 133 ft·lb) – 185 N·m (18.8 kg·m, 136 ft·lb)**

With adjusting cap and spring washer

 : **100 N·m (10 kg·m, 74 ft·lb) – 105 N·m (11 kg·m, 77 ft·lb)**

**CAUTION:**

- **Since the drive shaft is assembled by press-fitting, use the tightening torque range for the wheel hub lock nut.**
- **Be sure to use torque wrench to tighten the wheel hub lock nut. Never use a power tool.**

**NOTE:**

Wheel hub lock nut tightening torque does not over torque for avoiding axle noise, and does not less than torque for avoiding looseness.

- Perform the final tightening of each of parts under unladen conditions, which were removed when removing wheel hub and bearing assembly and axle housing.
- When installing the spring washer, face the identification paint mark to the wheel hub and bearing assembly side. (With adjusting cap and spring washer for wheel hub lock nut)
- When installing the adjusting cap, check that there must be no play. (With adjusting cap and spring washer for wheel hub lock nut)
- Never reuse cotter pin, wheel hub lock nut, and spring washer (if equipped).

### Disassembly and Assembly

INFOID:000000004670166

### DISASSEMBLY

Rear Final Drive Side

1. Fix shaft with a vise.

**CAUTION:**

**Protect shaft when fixing with a vise using aluminum or copper plates.**

2. Remove boot bands, and then remove boot from housing.
3. Put matching marks on housing and shaft.

**CAUTION:**

**Use paint or similar substance for matching marks. Never scratch the surface.**

## REAR DRIVE SHAFT

### < REMOVAL AND INSTALLATION >

4. Remove stopper ring with suitable tool, and pull out housing.

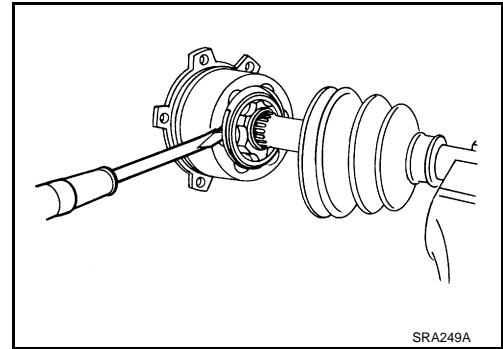

5. Put matching marks on ball cage/steel ball/inner race assembly and shaft.

**CAUTION:**

**Use paint or similar substance for matching marks. Never scratch the surface.**

6. Remove snap ring, then remove ball cage/steel ball/inner race assembly from shaft.
7. Remove boot from shaft.

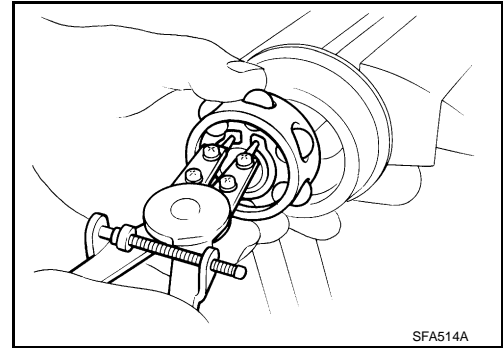

### Wheel Side

1. Remove dust shield from drive shaft.
2. Fix shaft with a vise.  
**CAUTION:**  
**Protect shaft when fixing with a vise using aluminum or copper plates.**

3. Remove boot bands. Then remove boot from joint sub-assembly.
4. Screw the drive shaft puller (A) 30 mm (1.18 in) or more into the thread of joint sub-assembly, and pull joint sub-assembly with a sliding hammer (B) from shaft.

**CAUTION:**

- If joint sub-assembly cannot be removed after five or more unsuccessful attempts, replace shaft and joint sub-assembly as a set.
- Align sliding hammer and drive shaft and remove them by pulling directory.

5. Remove circular clip from shaft.
6. Remove boot from shaft.

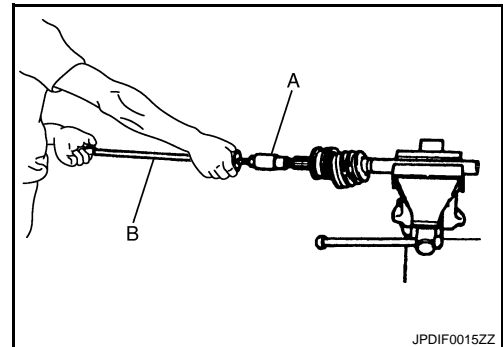

### ASSEMBLY

#### Rear Final Drive Side

1. Remove old grease on housing with paper paste.
2. Install new boot and boot band to shaft.  
**CAUTION:**
  - Wrap serrated part of shaft with tape to protect from damage.
  - Never reuse boot and boot band.
3. Remove the tape wrapped around the serrated on shaft.

## REAR DRIVE SHAFT

### < REMOVAL AND INSTALLATION >

4. Install ball cage/steel ball/inner race assembly (1) to shaft (2), and secure them tightly with a snap ring (3).

**CAUTION:**

**Never reuse snap ring.**

**NOTE:**

Align matching marks painted when ball cage/steel ball/inner race assembly were removed.

5. Apply the appropriate amount of grease onto housing and slid surface.

**NOTE:**

Align matching marks painted when housing were removed.

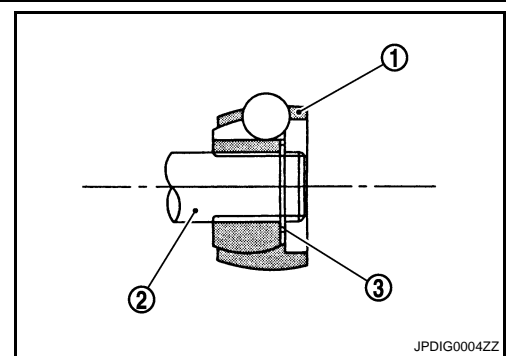

**Standard**

**Grease amount** : Refer to [RAX-17, "Drive Shaft"](#).

6. Install stopper ring to housing.
7. After installed, pull shaft to check engagement between housing and stopper ring.
8. Install boot securely into grooves (indicated by "\*" marks) shown in the figure.

**CAUTION:**

**If there is grease on boot mounting surfaces (indicated by "\*" marks) of shaft or housing, boot may come off. Remove all grease from the surfaces.**

9. To prevent the deformation of the boot, adjust the boot installation length (L) to the value shown below by inserting the suitable tool into the inside of boot from the large diameter side of boot and discharging inside air.

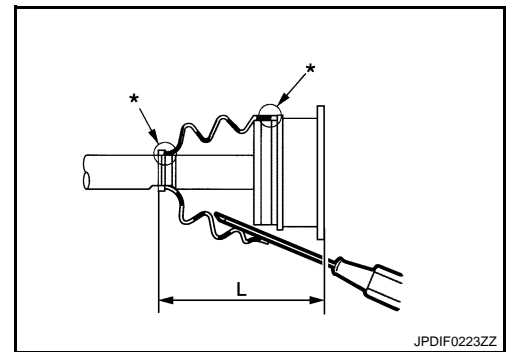

**Standard**

**Boots installed length (L)** : Refer to [RAX-17, "Drive Shaft"](#).

**CAUTION:**

- If the boot installation length is outside the standard, it may cause breakage of boot.
- Be careful not to touch the inside of the boot with the tip of tool.

10. Install new boot bands securely.

**CAUTION:**

**Never reuse boot band.**

- a. For one-touch clamp band
  - i. Secure large and small ends of boot with new boot bands as shown in the figure.

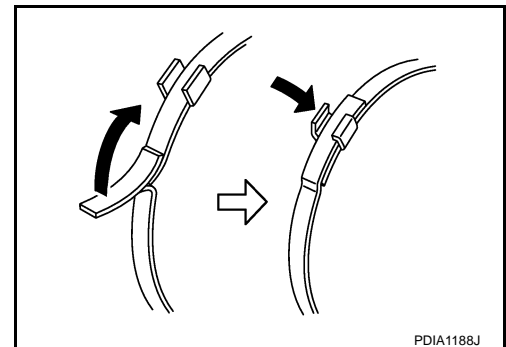

- b. For low profile type band

## REAR DRIVE SHAFT

### < REMOVAL AND INSTALLATION >

- i. Put boot band in the groove on drive shaft boot. Then fit pawls (←) into holes to temporary installation.

**NOTE:**

For the large diameter side, fit projection (A) and guide slit (B) at first.

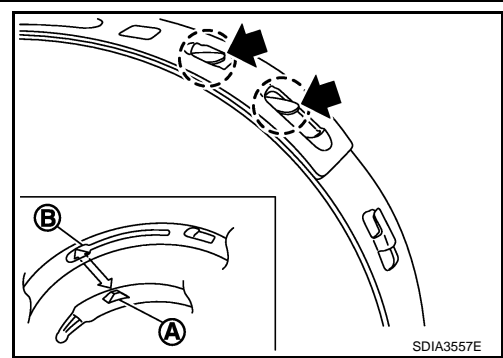

- ii. Pinch projection on the band with suitable pliers to tighten band.
- iii. Insert tip of band below end of the pawl.

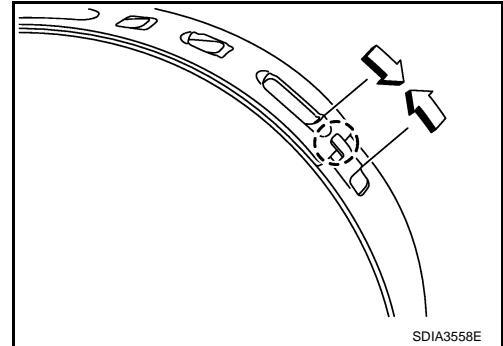

11. Secure housing and shaft, and then make sure that they are in the correct position when rotating boot. Install them with new boot band when the mounting positions become incorrect.

#### Wheel Side

1. Clean old grease on joint sub-assembly with paper waste.
2. Apply the specified amount of grease into joint sub-assembly serration hole until grease begins to ooze from ball groove and serration hole.

**CAUTION:**

**After applying grease, use a paper waste to wipe off old grease that has oozed out.**

3. Install new boot and boot band to shaft.

**CAUTION:**

- Wrap serrated part of shaft with tape to protect from damage.
- Never reuse boot and boot band.

4. Remove the tape wrapped around the serrated on shaft.
5. Position circular clip on groove at the shaft edge.

**CAUTION:**

**Never reuse circular clip.**

**NOTE:**

Drive joint inserter is recommended when installing circular clip.

6. Align both center axes of the shaft edge and joint sub-assembly. Then assemble shaft with circular clip joint sub-assembly.
7. Install joint sub-assembly to shaft using plastic hammer.

**CAUTION:**

**Confirm that joint sub-assembly is correctly engaged while rotating drive shaft.**

8. Apply the balance of the specified amount of grease into the boot inside from large diameter side of boot.

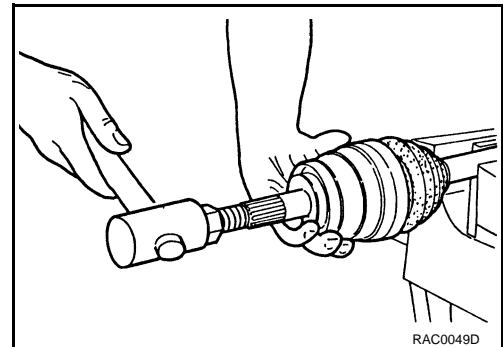

**Standard**

**Grease amount**

: Refer to [RAX-17, "Drive Shaft"](#).

# REAR DRIVE SHAFT

## < REMOVAL AND INSTALLATION >

9. Install the boot securely into grooves (indicated by “\*” marks) shown in the figure.

**CAUTION:**

**If grease adheres to the boot mounting surface (with “\*” mark) on the shaft or housing, boot may come off. Remove all grease from the surfaces.**

10. To prevent the deformation of the boot, adjust the boot installation length (L) to the specified value shown below by inserting the suitable tool into inside of the boot from the large diameter side of boot and discharging the inside air.

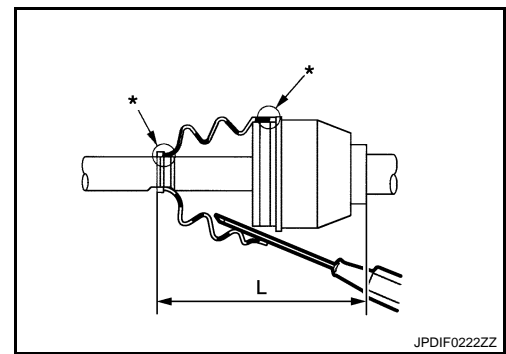

**Standard**

**Boots installed length (L)**

**: Refer to [RAX-17, "Drive Shaft"](#).**

**CAUTION:**

- If the boot installation length is outside the standard, it may cause breakage of boot.
- Be careful not to touch the inside of the boot with the tip of tool.

11. Secure the large and small ends of the boot with boot bands using the boot band crimping tool (A) [SST: KV40107300 ( - )].

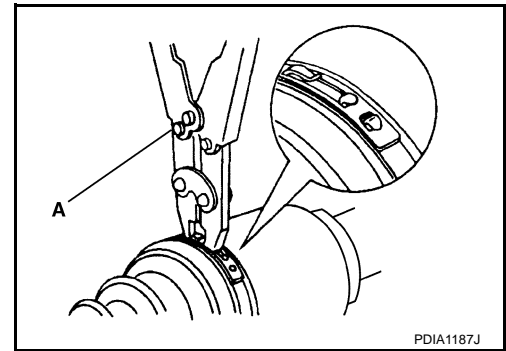

**NOTE:**

Secure boot band so that dimension (M) meets the specification as shown in the figure.

**Dimension “M” : 1.0 – 4.0 mm (0.039 – 0.157 in)**

12. Secure joint sub-assembly and shaft, and then make sure that they are in the correct position when rotating boot. Install them with boot band when boot installation positions become incorrect.

13. Install dust shield to drive shaft.

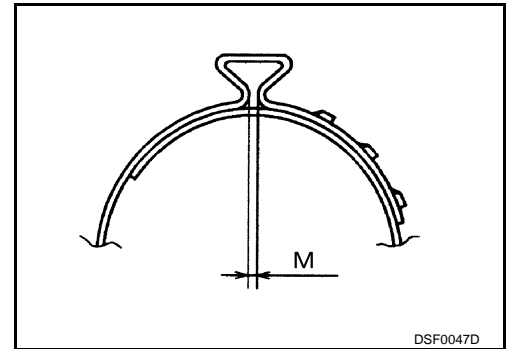

## Inspection

INFOID:000000004670167

### INSPECTION AFTER REMOVAL

- Move joint up/down, left/right, and in the axial direction. Check for any rough movement or significant looseness.
- Check boot for cracks or other damage, and also for grease leakage.
- If a malfunction is found, disassemble drive shaft, and then replace with new one.

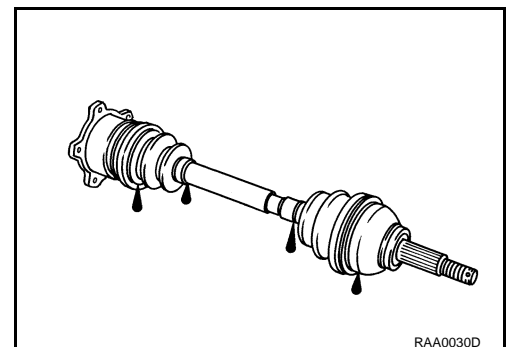



# SERVICE DATA AND SPECIFICATIONS (SDS)

< SERVICE DATA AND SPECIFICATIONS (SDS)

## SERVICE DATA AND SPECIFICATIONS (SDS)

### SERVICE DATA AND SPECIFICATIONS (SDS)

#### Wheel Bearing

INFOID:0000000004670168

Item	Standard
Axial end play	0.05 mm (0.002 in) or less

#### Drive Shaft

INFOID:0000000004670169

Item	Standard	
	Wheel side	Final drive side
Joint		
Grease quantity	110 – 120 g (3.38 – 4.23 oz)	124 – 134 g (4.37 – 4.73 oz)
Boots installed length	150.68 mm (5.93 in)	155 mm (6.10 in)

A  
B  
C  
RAX  
E  
F  
G  
H  
I  
J  
K  
L  
M  
N  
O  
P